

Note: CXX added on back of board

Title openQRP Transceiver - Receiver 1st/2nd Mixers & Detector		
Author Steven T Elliott www.openQRP.org		
File .\NewStuff\ ... openQRP_SCH_R05.dsn.autosave	Document	
Revision D	Date 12/5/2011	Sheets 1 of 9

### Active Audio Filter (690 Hz)

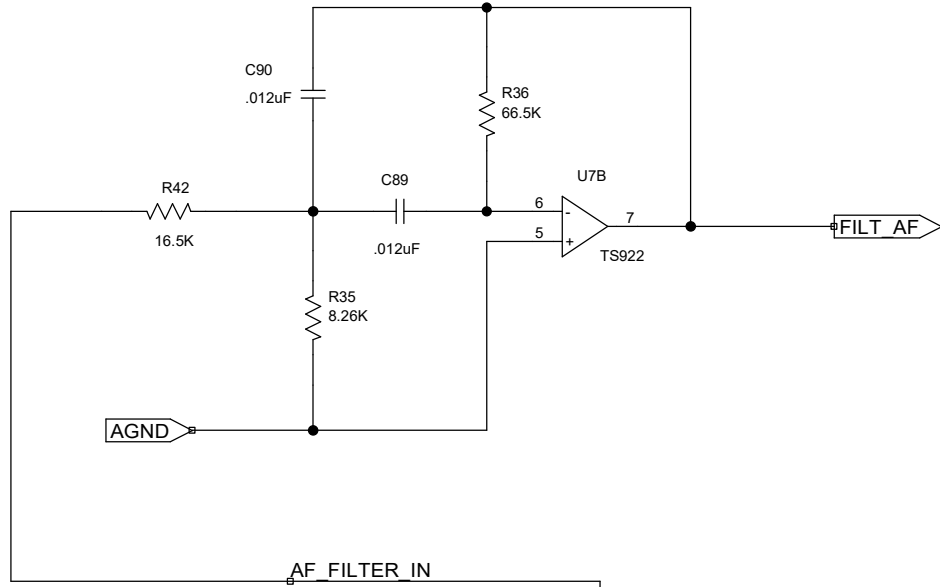

### Analog Ground Supply

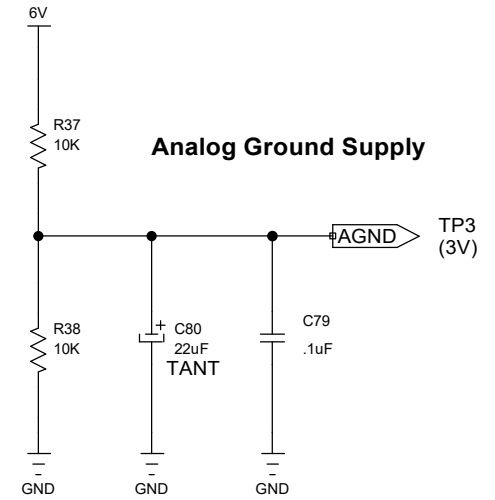

### 6V Regulated Supply

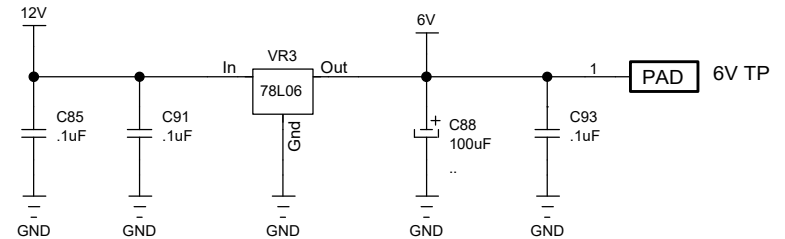

### Recovered Audio Select

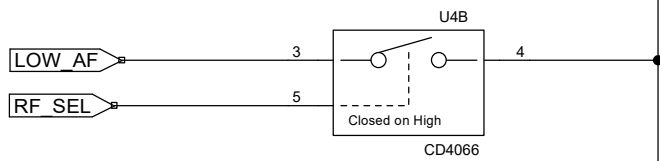

### Sidetone Select

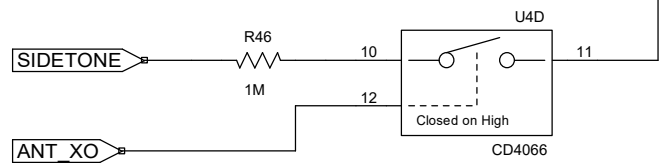

High when transmitting  
Low during receive

Title openQRP Transceiver - Four Pole Active Filter		
Author Steven T Elliott www.openQRP.org		
File .\NewStuff\ ... openQRP_SCH_R05.dsn.autosave	Document	
Revision D	Date 12/5/2011	Sheets 2 of 9

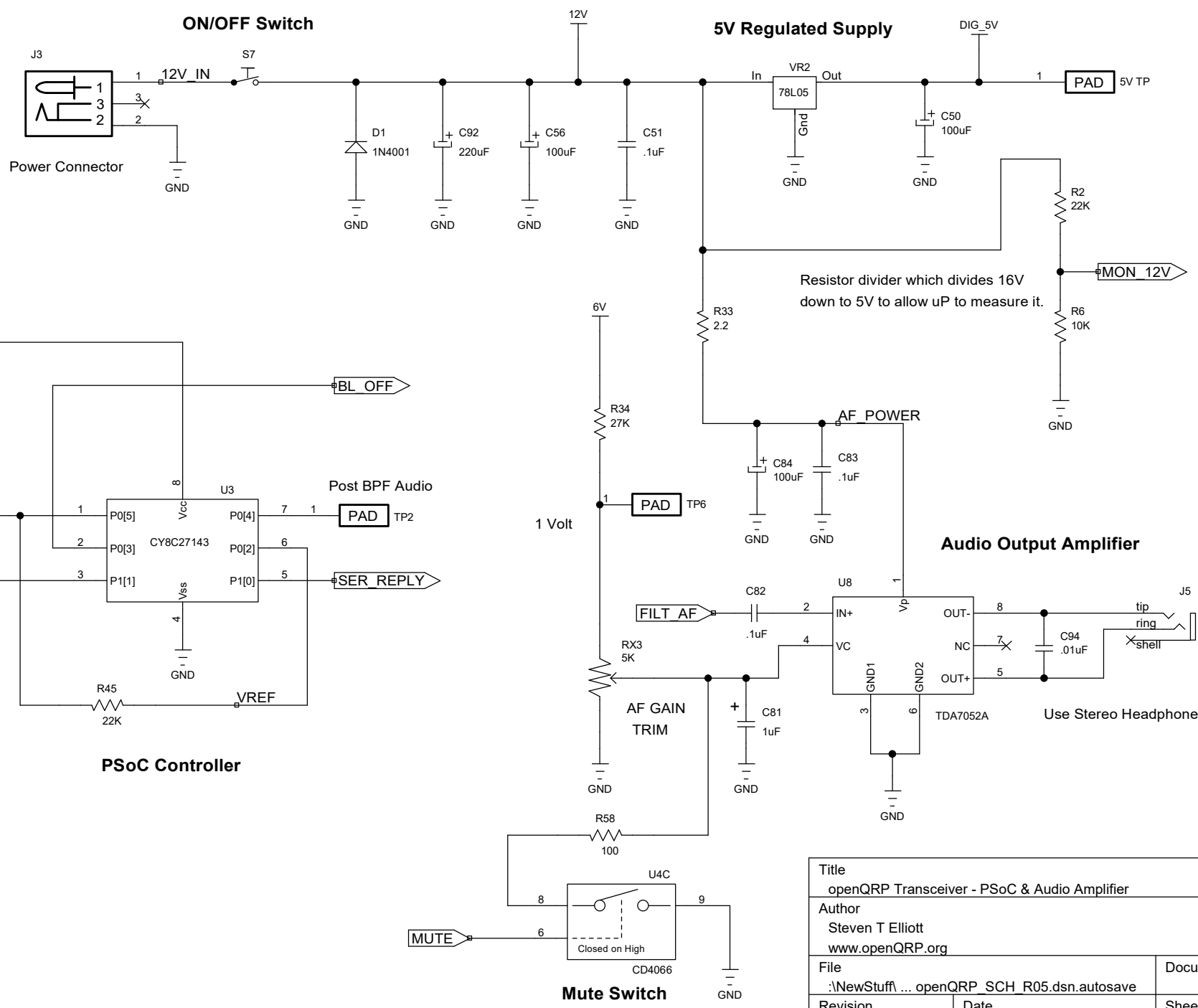

Title openQRP Transceiver - PSoC & Audio Amplifier		
Author Steven T Elliott www.openQRP.org		
File .\NewStuff\ ... openQRP_SCH_R05.dsn.autosave	Document	
Revision D	Date 12/5/2011	Sheets 3 of 9

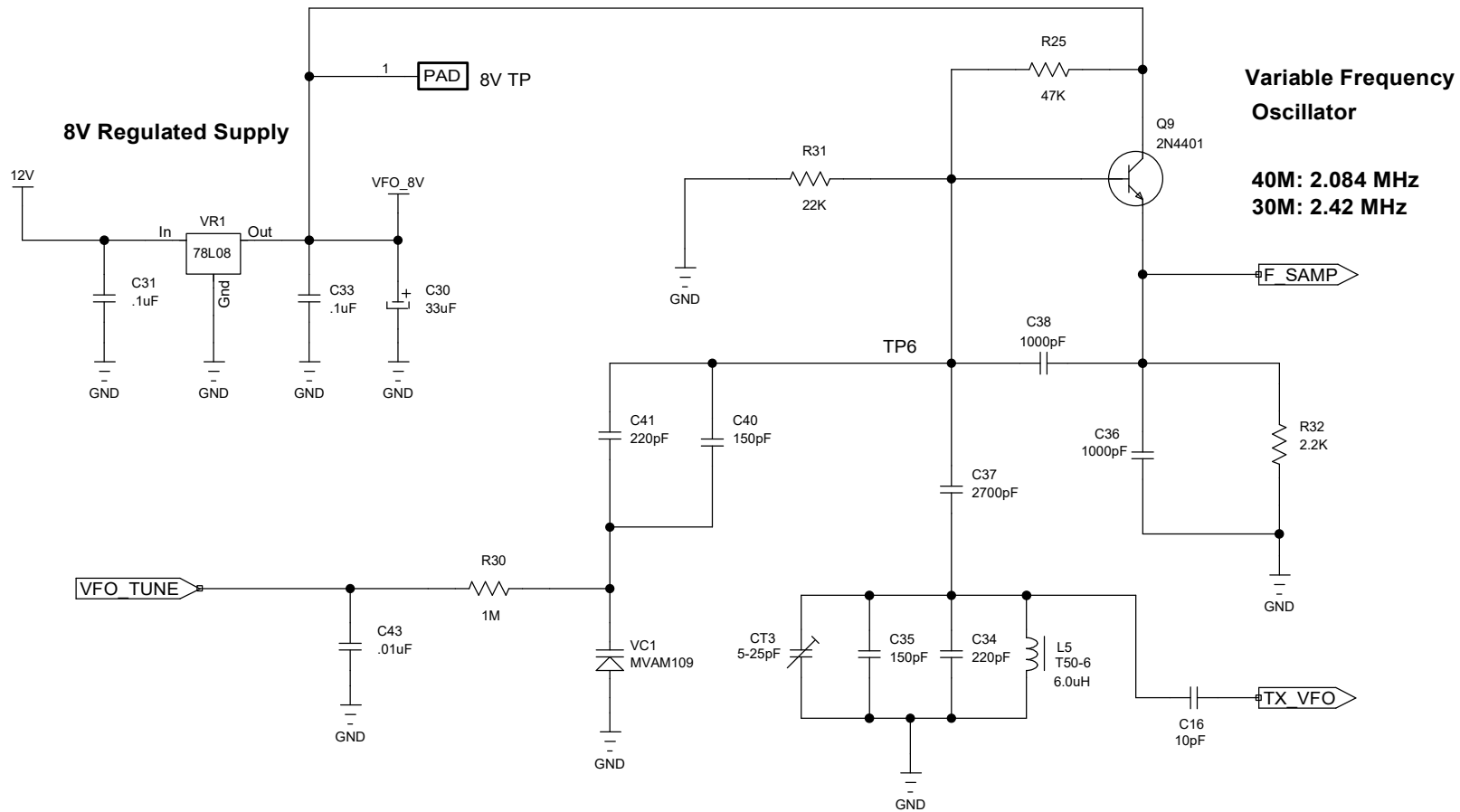

**Variable Frequency Oscillator**

**40M: 2.084 MHz  
30M: 2.42 MHz**

**40M Values Shown**

Title openQRP Transceiver - VFO with Varactor Tuning		
Author Steven T Elliott www.openQRP.org		
File :\NewStuff\ ... openQRP_SCH_R05.dsn.autosave	Document	
Revision D	Date 12/5/2011	Sheets 4 of 9

### TUNE and RIT Controls

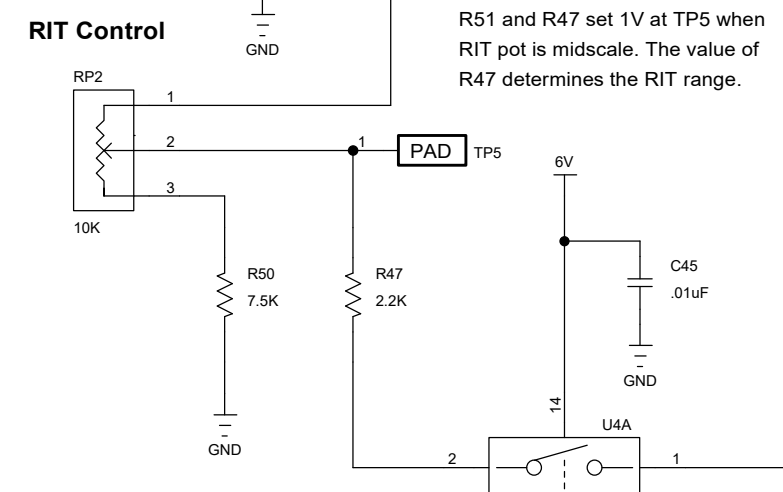
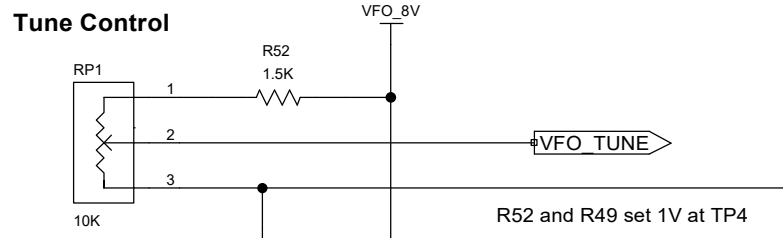

**RIT Calibration**  
Turn RIT off and adjust RP2 to get 1.0V at TP5. Then set RIT knob so that its arrow is centered.

### RIT On/Off Switch

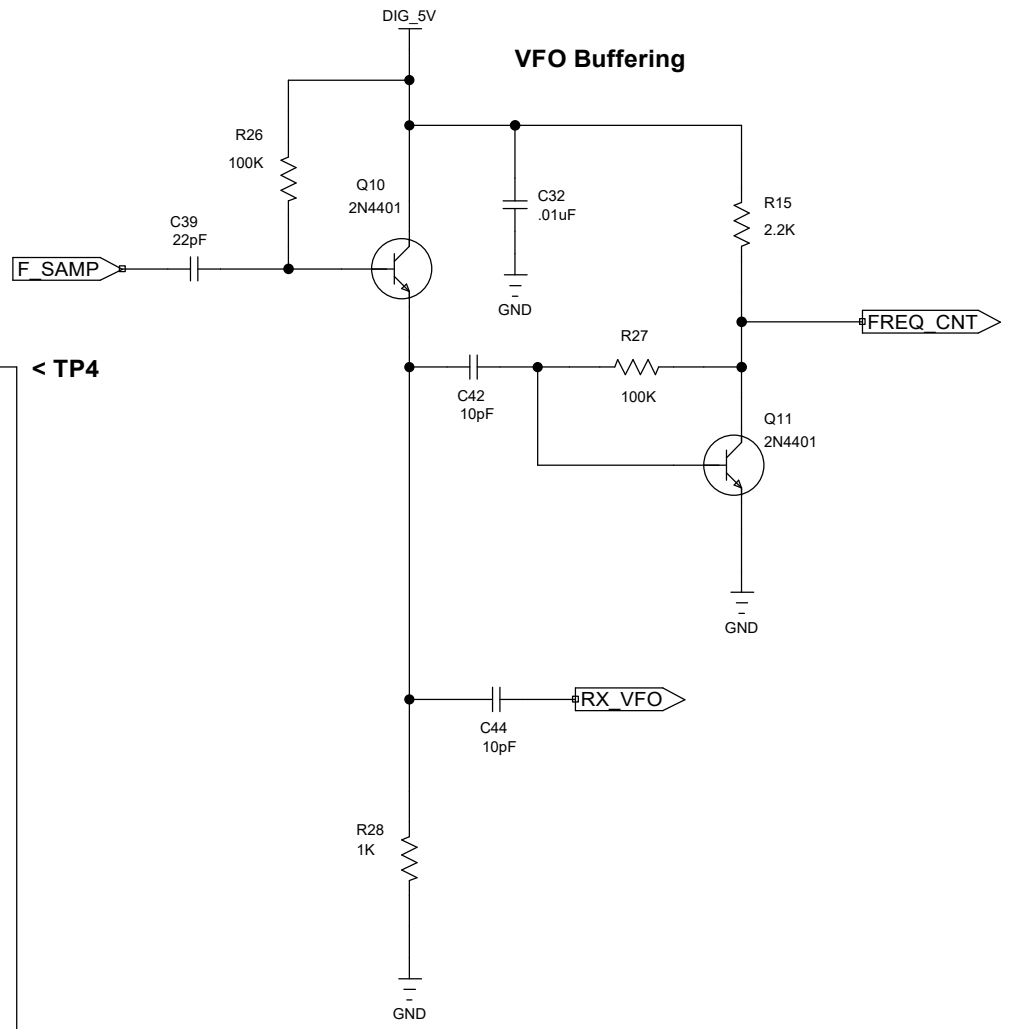

Title openQRP Transceiver - VFO Buffer Amp		
Author Steven T Elliott www.openQRP.org		
File .\NewStuff\ ... openQRP_SCH_R05.dsn.autosave	Document	
Revision D	Date 12/5/2011	Sheets 5 of 9

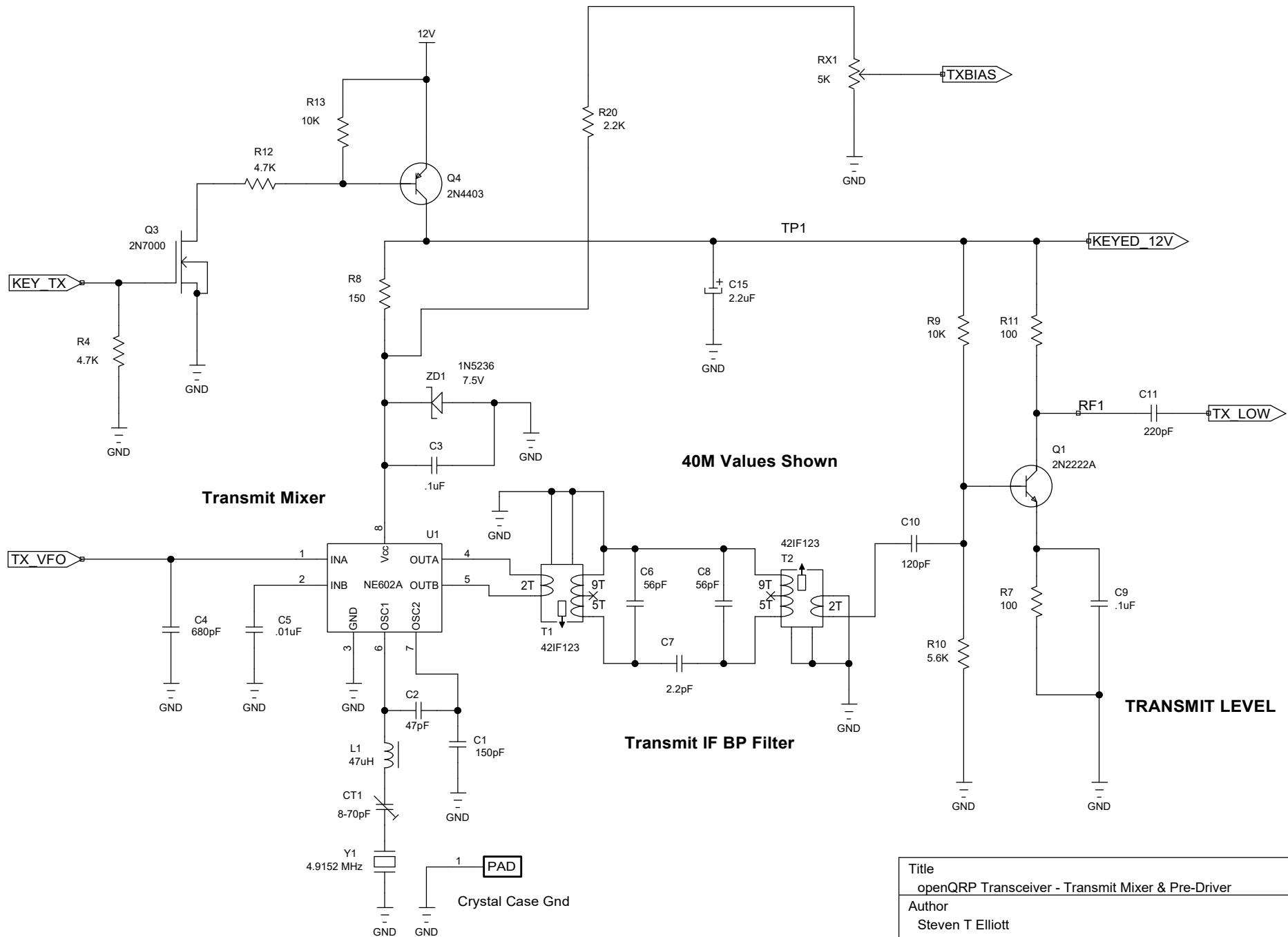

Title openQRP Transceiver - Transmit Mixer & Pre-Driver		
Author Steven T Elliott www.openQRP.org		
File .\NewStuff\... openQRP_SCH_R05.dsn.autosave	Document	
Revision D	Date 12/5/2011	Sheets 6 of 9

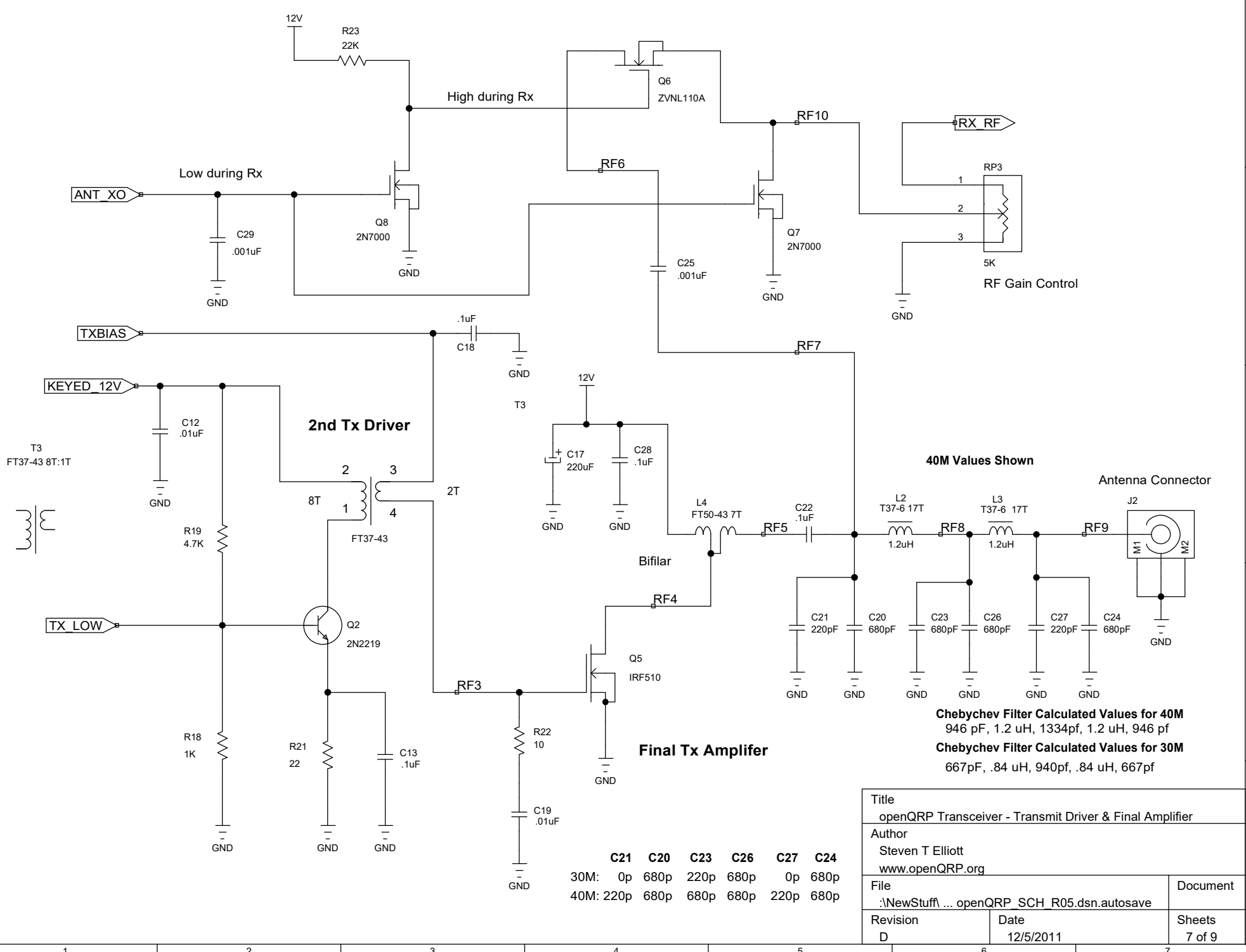

40M Values Shown

**Chebyshev Filter Calculated Values for 40M**  
 946 pF, 1.2 uH, 1334pF, 1.2 uH, 946 pF  
**Chebyshev Filter Calculated Values for 30M**  
 667pF, .84 uH, 940pF, .84 uH, 667pF

	C21	C20	C23	C26	C27	C24
30M:	0p	680p	220p	680p	0p	680p
40M:	220p	680p	680p	680p	220p	680p

Title openQRP Transceiver - Transmit Driver & Final Amplifier		
Author Steven T Elliott www.openQRP.org		
File .:NewStuff\ ... openQRP_SCH_R05.dsn.autosave	Document	
Revision D	Date 12/5/2011	Sheets 7 of 9

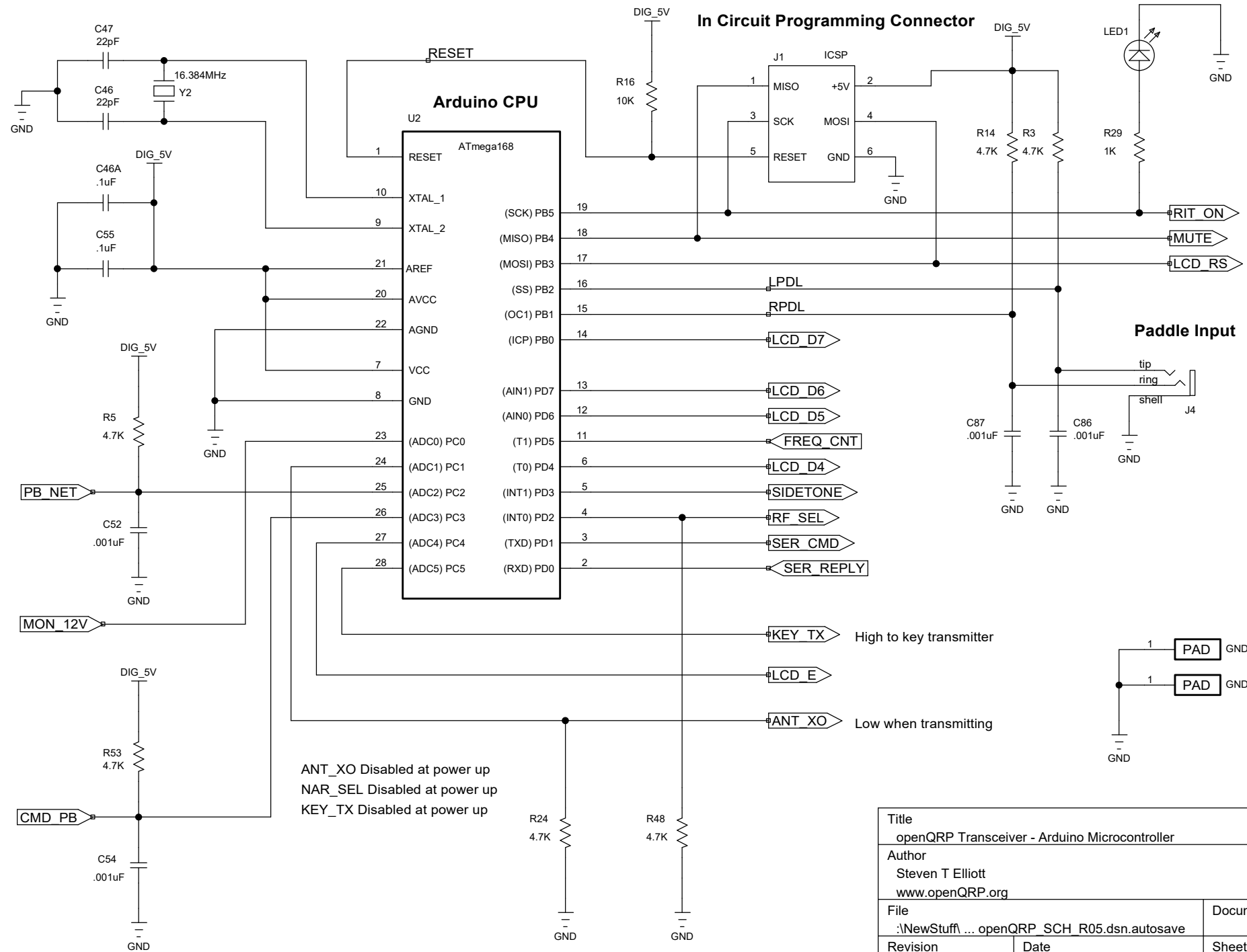

Title openQRP Transceiver - Arduino Microcontroller		
Author Steven T Elliott www.openQRP.org		
File .:NewStuff\... openQRP_SCH_R05.dsn.autosave	Document	
Revision D	Date 12/5/2011	Sheets 8 of 9



### Front Panel Pushbutton Switches

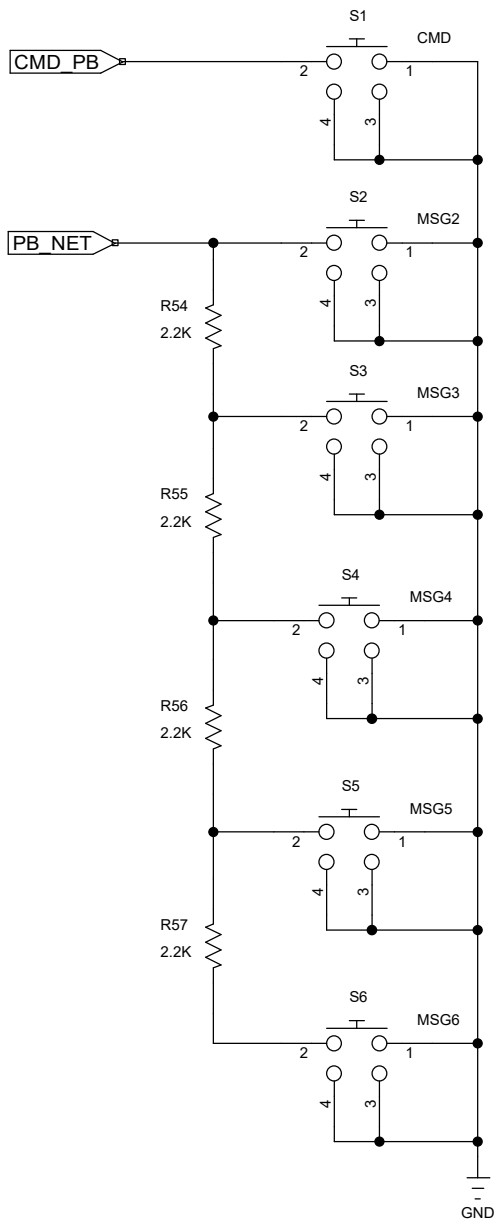

### LCD Display

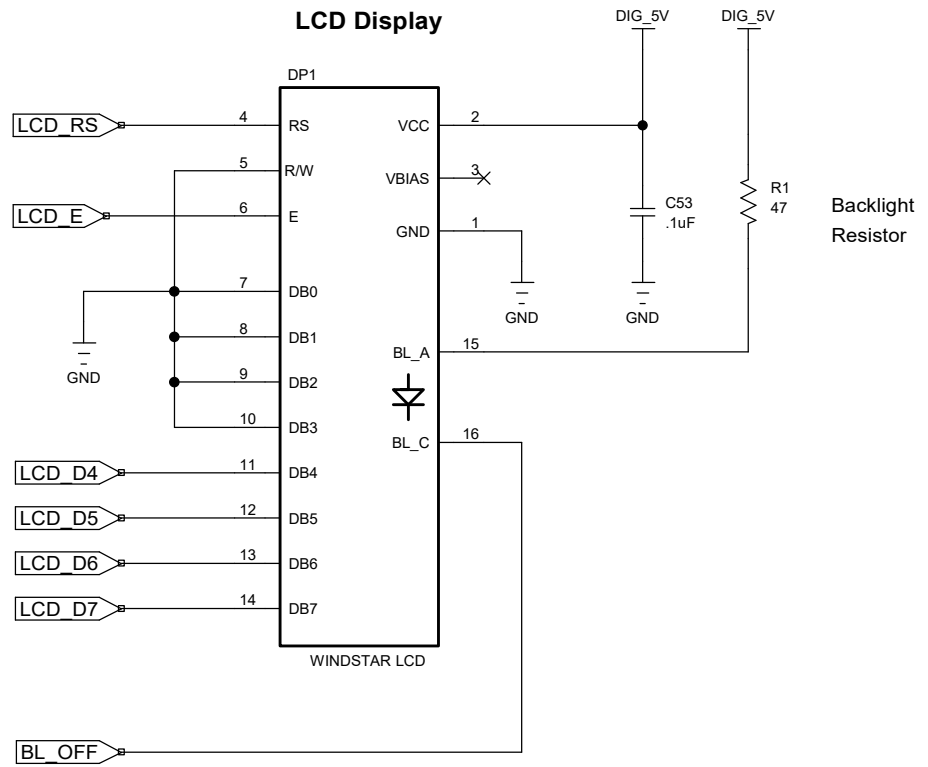

### Mounting Holes

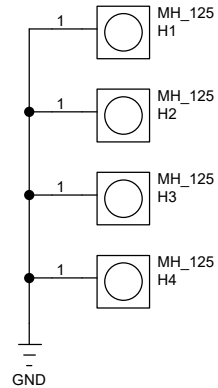

### LCD Contrast Control

Title openQRP Transceiver - LCD Display & Pushbutton Switches		
Author Steven T Elliott www.openQRP.org		
File :\NewStuff\... openQRP_SCH_R05.dsn.autosave	Document	
Revision D	Date 12/5/2011	Sheets 9 of 9