

Features

- This is an oscillator not a Morse keyer
- Input source can be a keyer or straight key
- Near Sine wave tone output
- CPO Tone Volume Control
- CPO Tone Frequency Control
- Use headphones or external speaker
- 1/8" Audio output Jack
- External speaker connection pads
- RCA Key Input Jack
- RCA Key Sync Input Jack
- Requires external 9 VDC power

Description

The CPO is a versatile code practice oscillator with synthesized sine wave output and adjustable frequency and volume controls. An RCA input jack is provided that can be driven by practically any keyer or straight key. A single chip microcontroller provides all of the functionality of the CPO including sine wave generation. It is implemented in a Microchip PIC12F1501 single chip microcontroller. Two or more CPOs may be connected together in a local network to simulate on air operation for practice purposes.

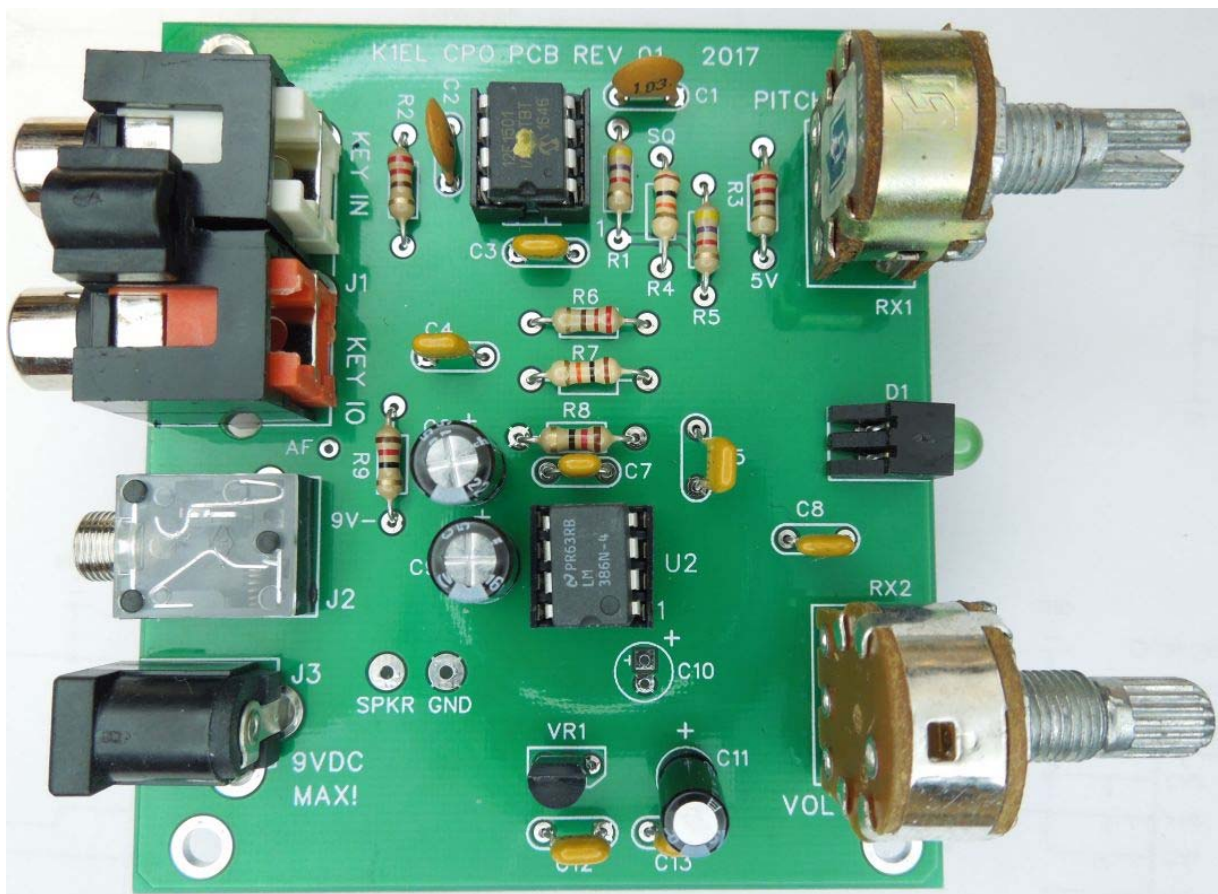
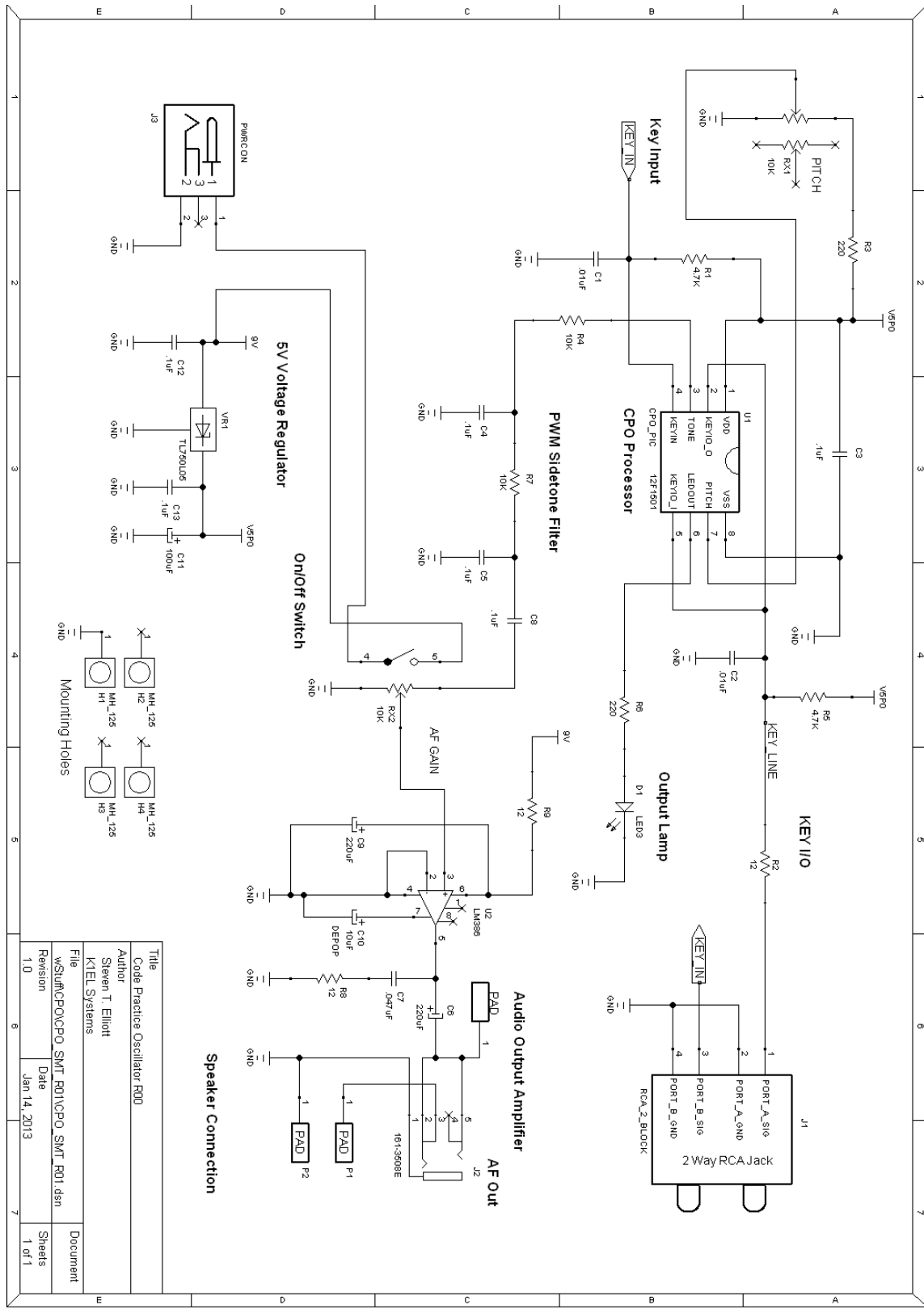

Figure 1 – Assembled CPO Board

Construction

Building a CPO kit is quite easy. All components are through hole and ¼ watt resistors are used to make it easier to identify color codes. It will take a beginner about an hour to build the kit, previous soldering experience is suggested. All builders should read through Appendices A, B, and C to review our kit construction hints.

CPO Schematics



CPO Kit Assembly

Parts Inventory

U1	- PIC12F1501 CPU 8 pin DIP
VR1	- TL7505L05 5.0V regulator TO92
U2	- LM386 Audio Amplifier 8 pin DIP
R3, 6	- 220 Ω 1/4 watt (red red brown)
R2, 8, 9	- 12 Ω 1/4 watt (brown red black)
R4, 7	- 10K 1/4 watt (brown black org)
R1, 5	- 4.7K Ω 1/4 watt (yellow violet red)
J3	- Power connector
P1	- DC Power Plug
J2	- RCA input jack block
J4	- 1/8" audio jack

C11	- 100 uF electrolytic capacitor
C3,4,5,	- .1 uF ceramic capacitor 104
C8,12,13	
C1,2	- .01 uF ceramic capacitor 103
C7	- .047 uF ceramic capacitor 473
C6, 9	- 220 uF electrolytic capacitor
C12	- This part is not installed
D1	- Right angle LED

RX1	- 10K potentiometer (Pitch)
RX2	- 10K potentiometer / switch (Vol)

2 pc	- 8 Pin DIP Socket
1 pc	- CPO PC board

PCB Assembly

Install and solder resistors first, R1 through R9. Color codes noted above.

Install and solder both 8 pin DIP sockets at U1 and U2. Orient the index mark as indicated by the arrows in Figure 2.

Install and solder Caps: C1 to C11 **Observe polarity on electrolytics C6, 9 and 11**: Long lead goes through the PCB's square hole.

Install and solder VR1 with the flat side oriented as shown in Figure 3.

Install and solder the following, carefully aligning each with the PCB's silkscreen:

- 1) Power jack J3
- 2) Dual RCA jack block, J1
- 3) Right Angle LED D1
- 4) 1/8" Audio jack J2

Install both board mounted 10K potentiometers RX1 and RX2. RX1 has five pins while RX2 has six. You may have to bend the pins so they fit correctly in the PCB holes. Make sure all the leads make it through the board before soldering them in place.

Install both 8 pin ICs; U1 (PIC12F1510) has a dot while U2 (LM386) does not.

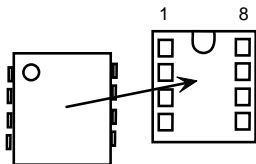

Test Procedure

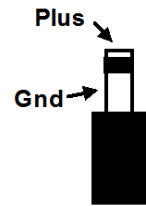

Make up a power cable using the power plug P1, Plus Volts goes to center pin and Ground goes to barrel.

Attach an RCA lead to the key input jack and plug in power cable at J3. Plug in headphones at J2. Turn RX2 fully counter-clockwise to make sure on/off switch is off. Double check polarity and apply 9 volts to the power cable. Turn RX2 to power on. Check the 9V test point on the PC board to verify the board has power. Turn RX2 fully counter-clockwise and RX1 mid scale.

Short the end of the RCA cable and you should hear a tone in the headphones. You will need to adjust the volume to a suitable level using RX2. Adjust the frequency control RX1 and you should hear the tone's pitch change. Move the RCA plug to the SYNC input and short the RCA cable end and you should hear the tone again. If you are using an external 8 ohm speaker, attach it to the SPKR GND pads on the PCB. When you unplug the headphones the speaker will be enabled.

If you encounter problems note that the most common source of problems is a missed solder connection, Also look misplace parts and solder shorts. Refer to the PCB image (Figure 4) and the schematic on page 2 for help.

CPO PCB Images

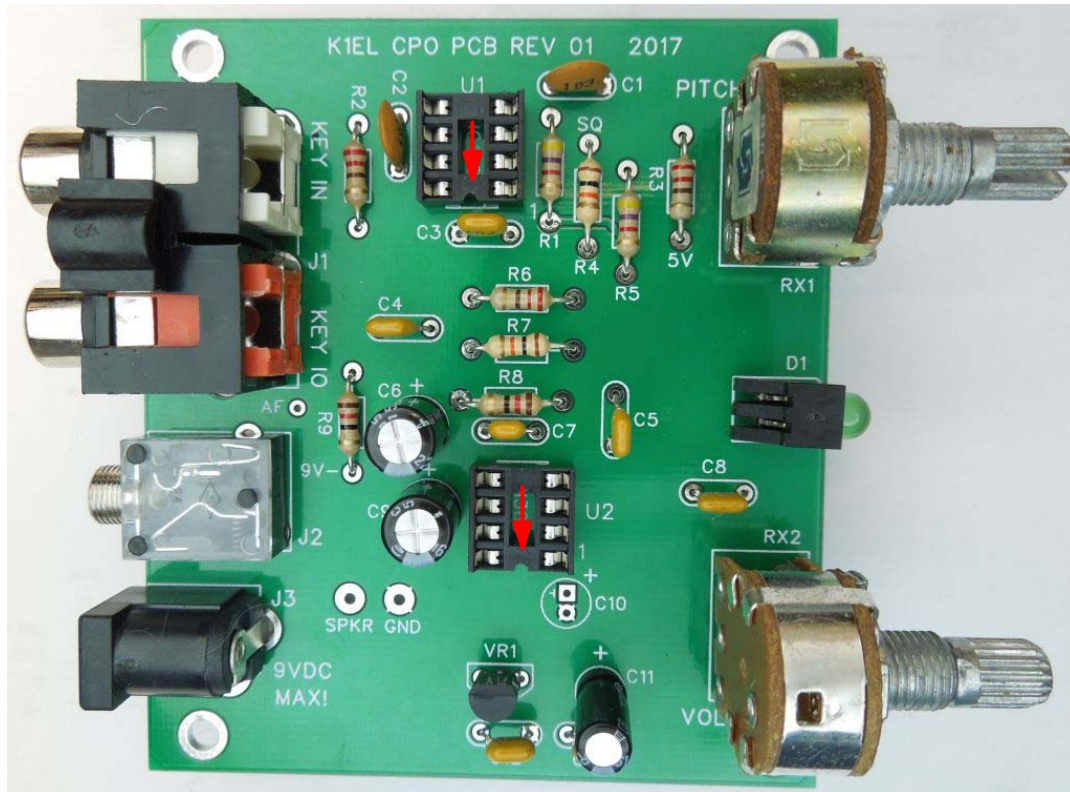

Figure 2 – Assembled CPO Board Close Up



Figure 3 – Assembled CPO Board Close Up, Top Half

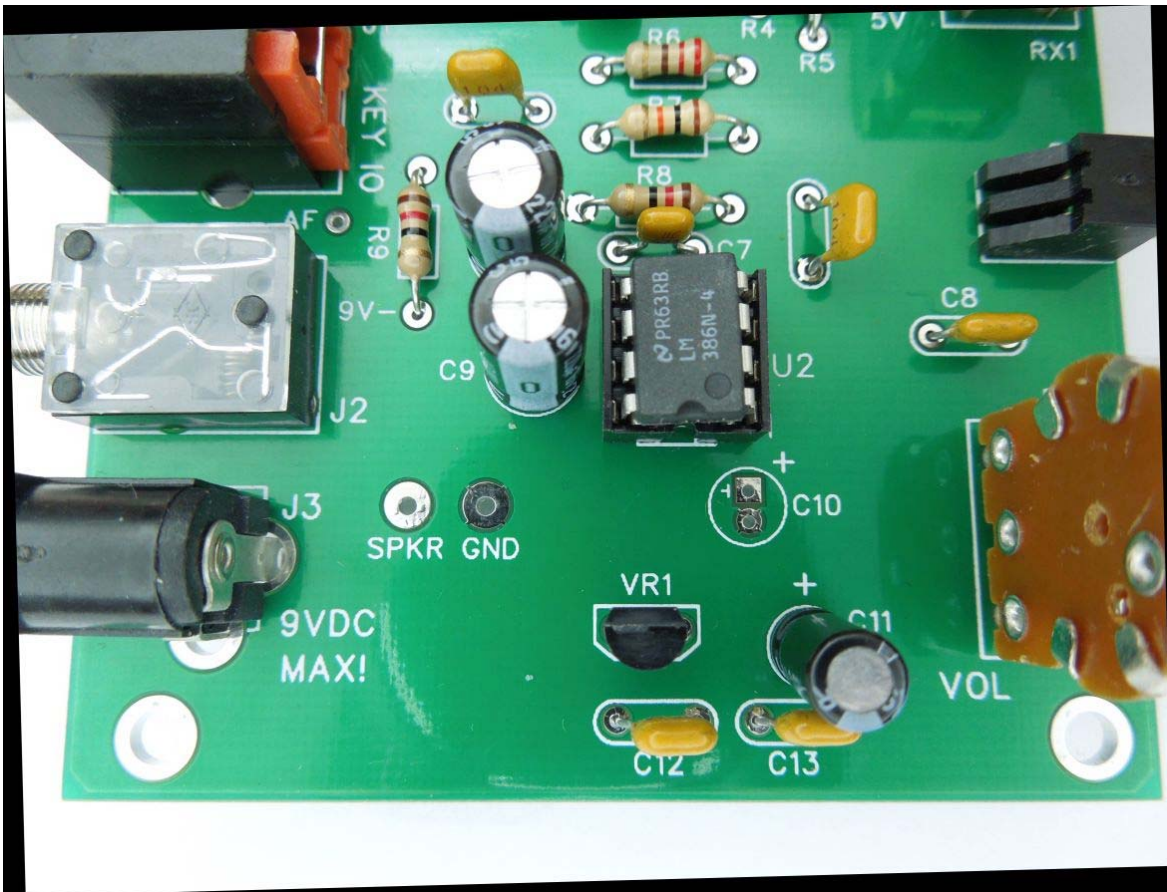

Figure 3 – Assembled CPO Board Close Up, Bottom Half

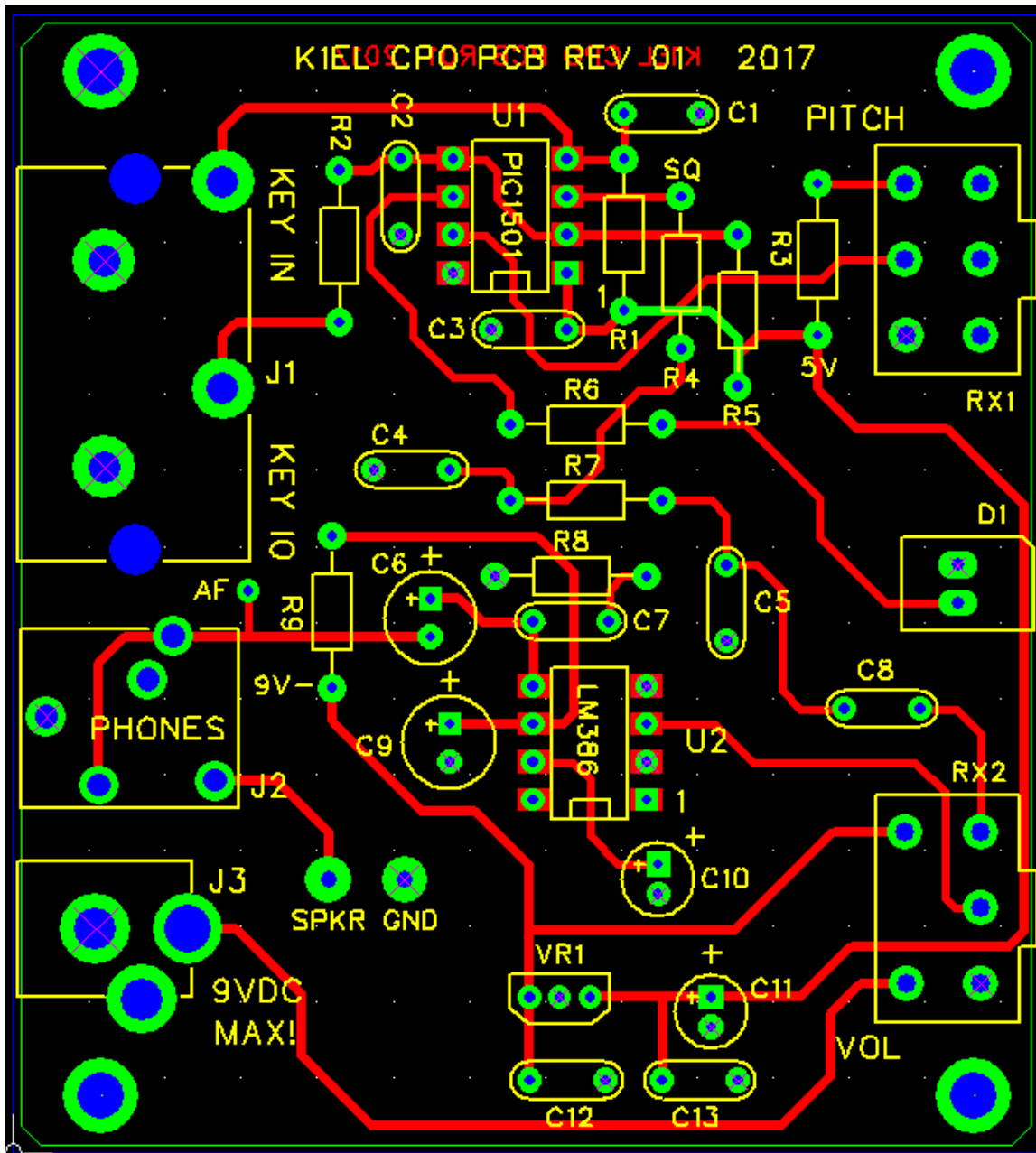

Figure 4 – Printed Circuit Board Image

Operation and Connection Guide

Both the Key In and Key IO jacks will key the oscillator when either is grounded. The Key I/O jack is an open collector connection so it can act as both an input and an output, When the Key In jack is grounded, the Key I/O line will be grounded also. This is the basis for Key Sync mode whereby several CPOs can be networked together by sharing their KEY IO lines. (see page 7).

Two audio outputs are provided, a hard wired speaker connection (SPKR) and an 1/8 inch stereo headphone jack. Always turn the audio level down before plugging headphones in and then slowly increase the output to a comfortable level. Note that when something is plugged into the headphone jack, the external speaker is automatically disabled.

Key Sync Mode Description

A handy feature that is indispensable in Morse Code classes is the key sync mode. It allows multiple CPOs to be wired together in a virtual Morse network. When multiple CPOs are connected together, keying one will cause the Morse tone to be heard in all other CPOs. If two CPOs send at the same time, the transmission will be garbled and that will encourage operators to use standard exchange practices. Key Sync cabling only requires simple two wire cables with an RCA plug at both ends. If more than two CPOs are networked together, RCA Y cables are required to bridge the central CPOs.

Key Sync Operation

This diagram illustrates a set of three CPOs connected in a network. The interconnecting cables are just simple two wire RCA cable, the middle station would have a Y cable that allows it to be connected to two other CPOs. The CPOs could be located in different rooms or up to 100 feet away. When any station keys their CPO, a tone will be heard both locally and at the other two CPOs. Volume and frequency settings only affect the local station allowing each station to set their CPO to their liking, If two stations key at the same time they will collide resulting in unreadable Morse. This is similar to what happens when two stations send at the same time live on air. This greatly helps beginners understand and practice proper operating techniques

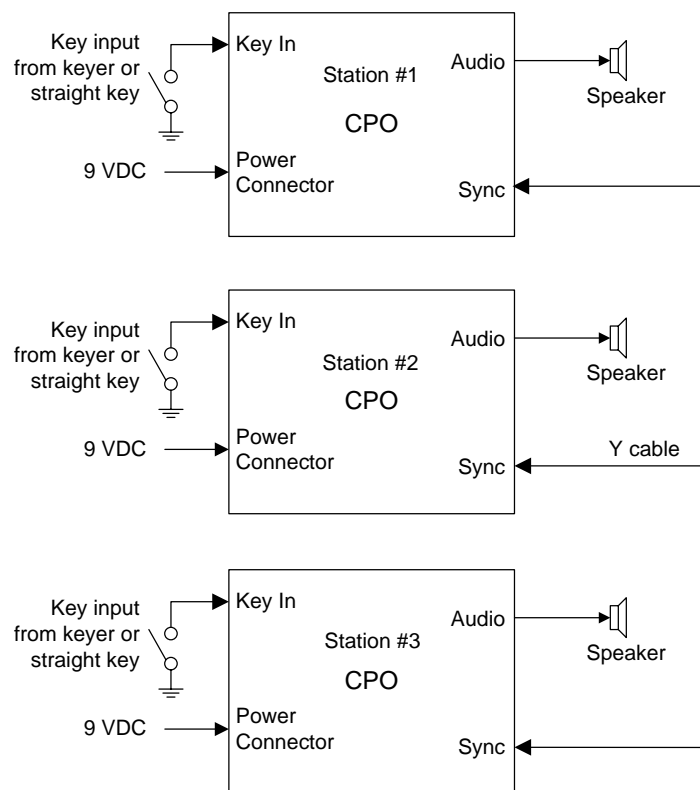

Figure 5 -Triple CPO Connection Diagram

Contact Information

The CPO keyer is fully guaranteed; if you are not satisfied please return the CPO for a full refund. Questions will be handled by snail-mail or e-mail via these addresses:

Steven T. Elliott K1EL
43 Meadowcrest Drive
Bedford, NH 03110 USA

or e-mail: k1el.kitsinfo@gmail.com

Watch the K1EL Systems Website for latest updates and new product offerings: <http://www.k1el.com>

Revision History

CPO Chip Rev A Original Release

Manual Rev B.0 – Created for R01 PC board version.

Index

Features.....	1
Description.....	1
Figure 1 – Assembled CPO Board.....	1
Construction.....	1
CPO Schematics.....	2
CPO PCB Images.....	4
Figure 2 – Assembled CPO Board Close Up.....	4
Figure 3 – Assembled CPO Board Close Up, Top Half.....	4
Figure 3 – Assembled CPO Board Close Up, Bottom Half.....	5
Figure 4 – Printed Circuit Board Image.....	6
Key Sync Mode Description.....	7
Key Sync Operation.....	7
Figure 5 -Triple CPO Connection Diagram.....	7
Contact Information.....	8
Revision History.....	8
Index.....	8
Appendix A - Kit Construction Hints.....	9
Appendix B - A Note about Safety.....	10
Appendix C - Soldering Basics.....	10

Appendix A - Kit Construction Hints

1. Find a good workspace.

It is essential that you have a good place to work on your kit,

You will need room to spread out your parts and have access to tools. Good lighting and ventilation is essential. A magnifying glass or visor is highly recommended.

2. Have the proper tools.

At a bare minimum you will need:

Small side cutters, flush cutters are a plus.

Small needle nosed pliers

Small flat blade & Philips head screw drivers

A good quality, 40-60Watt, temperature controlled Soldering Iron. The price has come down on these lately; you can buy a Weller WLC100 40W soldering station with adjustable temperature control for \$40 on Amazon.

3. Read the Instructions First.

Read through the assembly instructions completely and have everything on hand before you start. Inventory the kit parts carefully to make sure you have them all.

4. Follow the assembly instructions in order.

Although not always obvious, the order in which parts are added to a board is important and should be followed. Sometimes sections are installed and tested in order or there could be a mechanical clearance consideration.

5. Keep your Workplace Clean and Orderly.

Nothing spoils a kit building experience more than lost parts. Second to that is stray bits of dirt and metal that get into a printed circuit board assembly. Our PC boards are nicely plated and accept solder easily. There is no need to clean the board with steel wool before starting. A good rosin core solder will work fine do not use organic core solder unless you have the facility to clean off the flux after assembly. Lead free solder is recommended for health reasons.

6. Take your time.

There is no need to rush, enjoy the process and the end result will be much better. Moving too quickly or working when you are tired often leads to big mistakes which could be difficult if not impossible to fix.

Appendix B - A Note about Safety

Burns to your skin can be very painful and can lead to serious injury.

Burns to your eyes can be catastrophic.

Toxic fumes can cause serious harm.

Flying objects such as wire ends etc. can cause painful and serious injuries.

When building your kit please remember that Soldering Irons and Solder are used at High Temperatures !

Soldering Irons can remain hot for many minutes after being turned off. Never touch the tip to see if it is hot. Touch the tip to a wet pad to test for temperature.

Wear safety glasses to protect your eyes from flying objects.

Appendix C - Soldering Basics

1. Insert component leads into PCB holes and bend them back slightly to hold the part in place. You can either trim the lead now or wait till after the joint is soldered. I usually install several parts at one time and then solder and trim multiple leads.
2. Place a hot and clean iron tip against both the lead and pad as in Fig. A1.

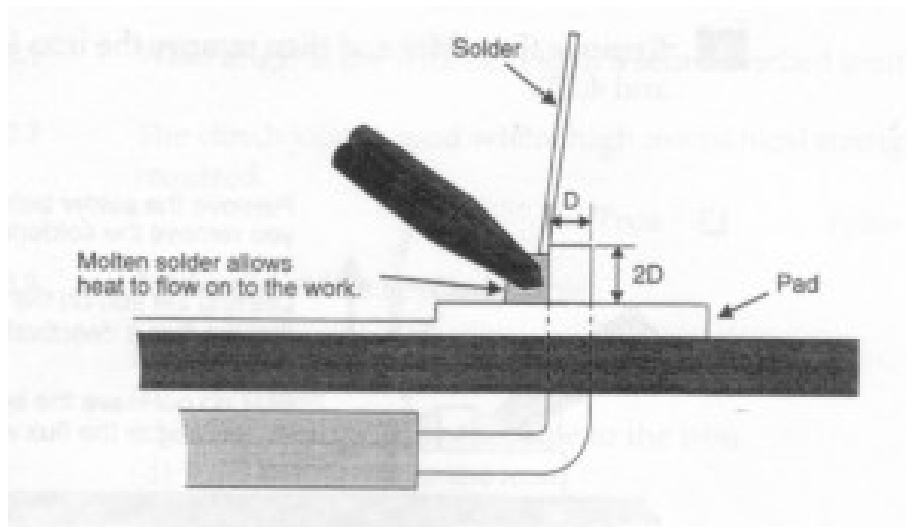

Figure C1 - Form a heat bridge

3. Create a heat bridge between the lead, the PCB pad and the iron by placing a small amount of solder on the tip.
4. Apply solder around the outside edge of the pad as in Fig. A2. If the pad and lead are at the correct temperature, the solder will flow around the connection.

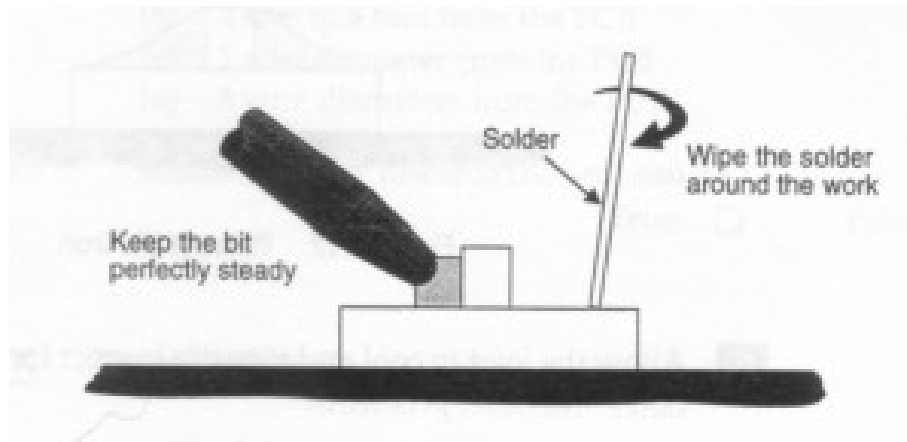

Figure C2 - Spread solder around the work

5. Remove the solder and then remove the iron.

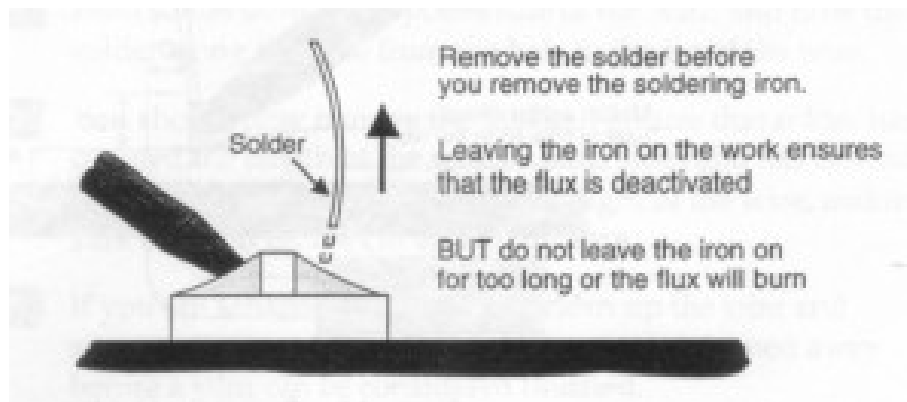

Figure C3 - Remove the solder

6. Allow the joint to cool and visually inspect for defects or other problems. You should have a solder joint with a bright shiny finish and a profile like that shown in the middle picture below.

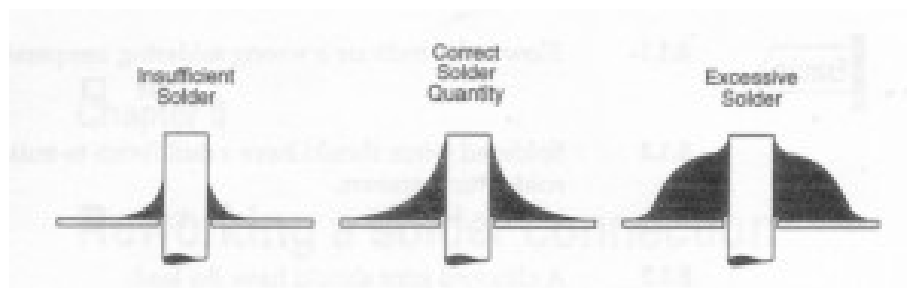

Figure C4 - Solder quantity comparison